

Model Number.
Located Here

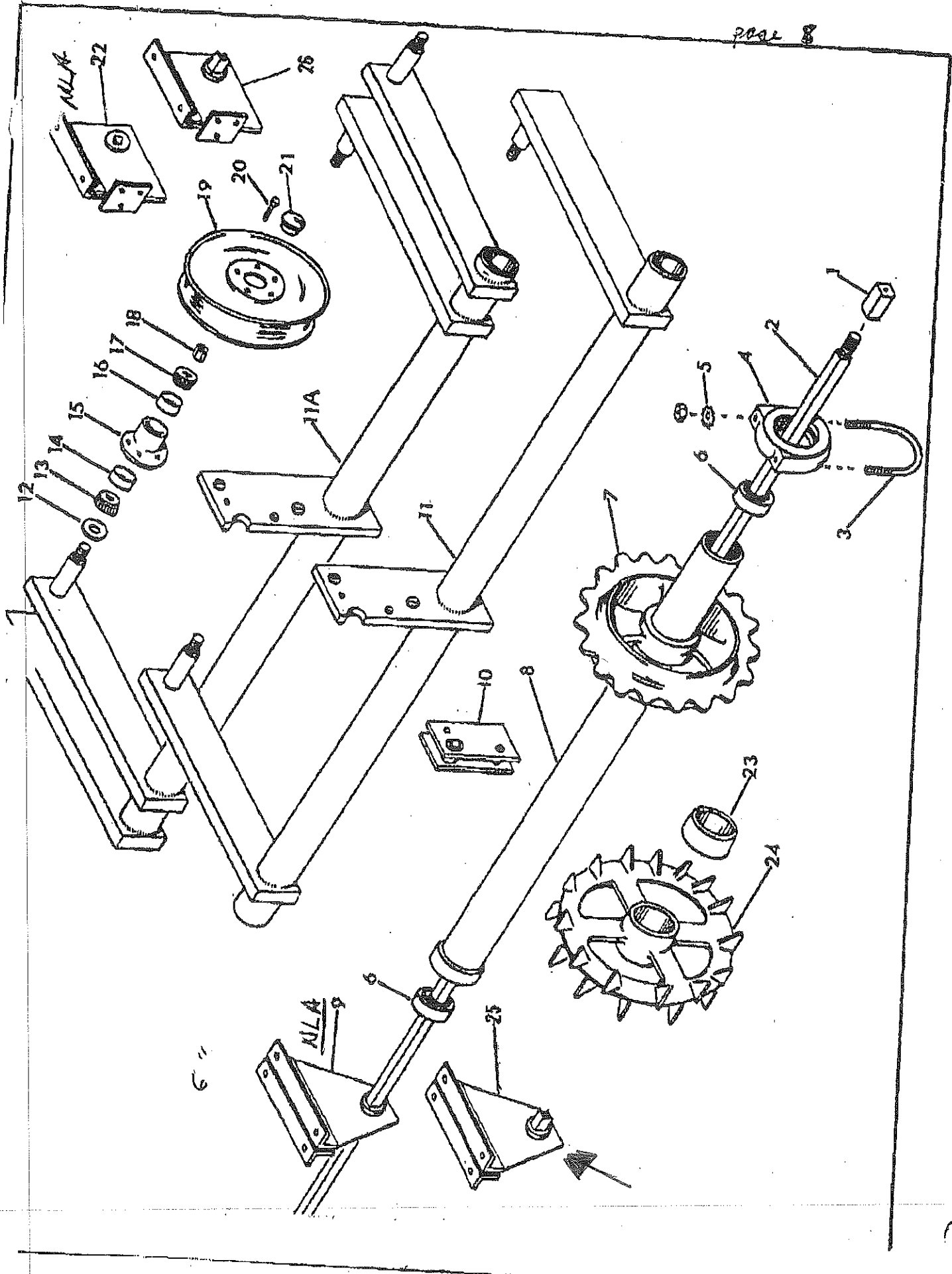

PMWT-124-01 THRU 124-03 TRANSPORT PULVI-MULCHER

Index No.	Part No.	Part Name	No. Used	Used On Model	Weight
1	1D-237	Capscrew, 1/2-13 NC x 2" Lg. (heat treated)	10	All	
2	8C-527	Capscrew, 1/2-13 NC x 1-1/2" Lg. (heat treated)	26	All	
		Lockwasher, 1/2" Med.	45	All	
		Nut, 1/2-13 NC	45	All	
3	2D-474	Capscrew, 5/8-11 NC x 1-3/4" Lg. (heat treated)	29	All	
		Lockwasher, 5/8" Med.	29	All	
		Nut, 5/8-11 NC	29	All	
4	7C-875	Capscrew, 1/2-13 NC x 2-1/2" Lg. (heat treated)	4	All	
5	3C-734	Carriage Bolt, 3/8-16 NC x 1-1/2" Lg.	32	All	
		Lockwasher, 3/8" Med.	36	All	
		Flat Washer, 3/8" Std.	32	All	
		Nut, 3/8-16 NC	36	All	
6	4D-44	L.H. Channel Assembly	1	All	70.0
7	9C-532	Rear Axle Mount <i>ALA</i>	2	01	4.0
8	7C-22	Bevel Washer	8	All	
9	5D-688	Rear Channel Assembly	1	All	89.7
10	5D-696	Scraper Bar	1	All	76.0
11	2D-110	Scraper	31	All	1.0
	3D-627	Center Scraper	1	All	1.3
12	4D-106	Dolly Drawbar	1	All	17.5
13	1C-234	Capscrew, 1/2-13 NC x 2" Lg.	5	All	
		Flat Washer, 1/2" Std.	6	All	
14	5D-694	Spring Tooth Shaft Bearing Assembly - Front	2	All	1.3
	4D-163	Spring Tooth Shaft Bearing Assembly - Rear	2	All	1.3
15	1D-236	Spring Tooth Shaft	2	All	80.8
16	4D-34	Center Truss Assembly	1	All	148.0
17	4D-23	Front Spring Tooth Shaft Support	1	All	16.8
18	4D-180	Front Center Bearing	1	All	9.9
	7C-309	Set Screw, 3/8-16 NC x 1-1/4" Lg. Sq. Hd.	1	All	
	7C-259	Rear Center Bearing (not shown)	1	All	8.8
	7C-427	Set Screw, 3/8-16 NC x 1-3/4" Lg. Sq. Hd.	1	All	
19	6C-956	Lift Handle Assembly	2	All	10.3
	5D-667	Capscrew, 3/8-16 NC x 2-1/2 Lg. (heat treated)	4	All	
20	7C-248	Spring Tooth Quadrant	1	All	6.0
	5D-27	Rear Spring Tooth Quadrant	1	All	
21	5D-699	R.H. Axle Support	1	All	12.8
	5D-700	L.H. Axle Support	1	All	12.8
22	4D-159	Bearing Cap (4D-158 With Lube Fitting)	2	All	4.6
23	3D-991	Bearing Assembly	2	All	2.5
24	5C-4	Spring Tooth (7/16" x 2" Wide)	19	All	9.5
25	8C-384	Clamp Bolt	19	All	.3
26	5C-78	Clamp Strap	19	All	.7
		Lockwasher, 1/2 Med.	38	All	
		Nut, 1/2-13 NC	38	All	
27	9C-531	Front Axle Mount <i>ALA</i>	2	01	5.5
28	4D-386	Reversible Shovel (Can be used on worn 5C-4 Spring Tooth)	All		1.1
	2C-628	Plow Bolt, 3/8-16 NC x 1-1/2" Lg. R.H. Sq. Neck C.S.	All		
29	9D-14	Leveler Support (Optional)		All	3.1
30	7C-178	Leveler (Optional)			31.9
31	5D-686	Front Channel Assembly	1	All	81.6
32	4D-46	R.H. Channel Assembly	1	All	70.0
34	5D-312	Spacer	1	All	
35	6D-538	Front Axle Mount (With Stub Shaft) <i>UPDATE</i>	2	02-03	7.0
36	6D-539	Rear Axle Mount (With Stub Shaft) <i>UPDATE</i>	2	02-03	5.5



THRU 180-05 TRANSPORT PULVI-MULCHER PAGE 4

Index No.	Part No.	Part Name	No. Used	Used On Model	Weight
1	9C-26	Axle Nut			
2	4D-89	Axle Assembly - Rear - 187" Long <i>MLA</i>	2	01-03	.9
	4D-90	Axle Assembly - Front - 183" Long <i>MLA</i>	1	01-03	68.0
3	9C-33	U-Bolt	1	01-03	66.0
4	9C-31	Axle Clamp	4	All	.6
5	9C-58	Lockwasher - 7/16 Med. External Tooth Nut, 7/16-14 NC	4	All	3.7
6	9C-16	Bearing	8	All	
7	8C-988	Pulverizer Wheel	8	All	1.7
8	4D-83	Pipe Axle Assembly - 88-5/16 Long - Includes Bearings	89	All	34.0
	4D-85	Pipe Axle Assembly - 92-5/16 Long - Includes Bearings	3	All	81.0
9	3D-987	Front Center Bracket	1	All	84.0
10	7C-611	Quick Hook-Up Assembly	1	01-03	12.6
		Capscrew, 1/2-13 NC x 1-3/4 Long	1	All	1.6
	5C-392	Locknut, 1/2-13 NC, Stover, Grade B	1	All	
	7D-434	Clevis Pin	1	All	
	4C-856	Hairpin Cotter	1	All	
11	6D-799	Transport Axle Assembly - Complete (Painted red)	1	All	
	6D-800	Transport Axle Assembly - Less Hubs (Painted red)	1	All	230.8
11A	6D-803	Dual Wheel Transport Axle Assembly - complete (Painted red) (Optional)			221.0
	6D-804	Dual Wheel Transport Axle Assembly - Less Hubs (Painted red) (Optional)	1		365.8
12	1D-273	Grease Seal	1		336.0
13	5C-480	Bearing Cone (#48548)	2	All	.1
14	5C-479	Bearing Cup (#48510)	2	All	.2
15	3D-870	Hub	2	All	.2
16	3C-166	Bearing Cup (#09195)	2	All	8.6
17	1D-274	Bearing Cone (#09081)	2	All	.2
18	3C-173	Slotted Nut, 3/4-16 NF, Light Cotter Pin, 5/32 x 1" Long	2	All	.3
			2	All	.1
19	4C-129	Wheel	2	All	
20	5C-100	Wheel Bolt	2	All	16.0
21	5C-908	Hub Cap	10	All	.1
22	5D-522	Rear Center Bracket	2	All	.8
25	6D-541	Front Center Bracket (With stub shaft) <i>UPDATE</i>	2	01-03	19.3
26	6D-542	Rear Center Bracket (With stub shaft) <i>UPDATE</i>	1	04-05	14.6
			1	04-05	21.3

USED ON CMWT & CCMT PULVI-MULCHER

23	4D-108	Spacer - 2-1/16 Wide (Used on 88-5/16 Long Pipe Axle Assembly)	14	CCMT	2.8
	2D-213	Spacer - 2-3/16 Wide (Used on 92-5/16 Long Pipe Axle Assembly)	28	CMWT	
7	8C-988	Pulverizer Wheel	42	CCMT	3.0
24	1D-927	Crowfoot Wheel	45	CMWT	34.0
			30	CMWT	41.0
			60	CCMT	